

INSPI SV

SHOPAROUND ISLAND WITH HIGH PRODUCT VISIBILITY.

Inspi serves and displays it's best as a shoparound island or multiplexed when low shelving unit is needed. Inspi SV58-121-140 is now multiplexable with Gusto serve over.



THE SIGN OF COOL QUALITY

Caring for the future

INSPI SV

VISION COLLECTION

How to read the code:

SV30-121-150-250
Front height Depth Height Length

Measures are centimeters.

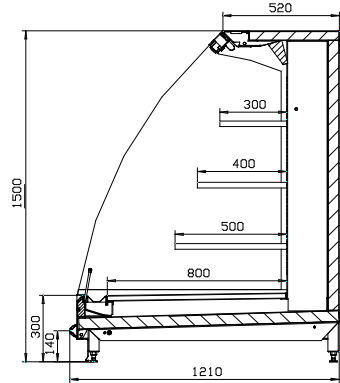

SV30-121-150 INSPI

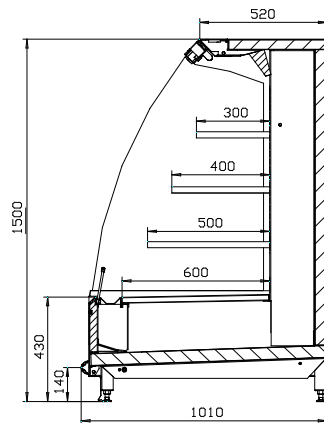

SV43-101-150 INSPI

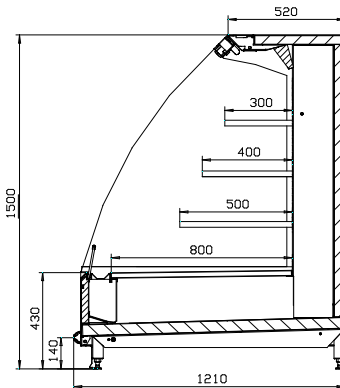

SV43-121-150 INSPI

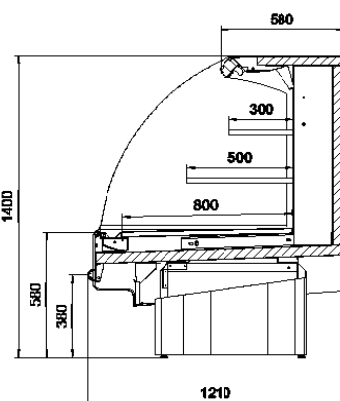

SV58-121-140-SO INSPI

STANDARD ACCESSORIES

- fan evaporator and expansion valves standard for R404A and CO2 refrigerant
- fans
- defrost heater
- defrost water outlet pipe in the cabinet length, external diameter 40 mm
- canopy lighting



Inspi SV with sliding doors.

TECHNICAL DATA

Front height	300, 430, 580 mm					
Height	1400, 1500 mm					
Air Temperature	+0...+2 °C or +2...+4 °C	Min. power input W	Max power input W ¹⁾	Length	Depth	Refr. area m ² ¹⁾
SV30-101-150-125		350	458	1250	1010	2.3
SV30-101-150-188		738	918	1875	1010	3.4
SV30-101-150-250		950	1166	2500	1010	4.5
SV30-101-150-375		1412	1772	3750	1010	6.8
SV30-121-150-125		350	458	1250	1210	2.5
SV30-121-150-188		738	918	1875	1210	3.8
SV30-121-150-250		950	1166	2500	1210	5.0
SV30-121-150-375		1412	1772	3750	1210	7.5
SV30-101-150-192-E		743	923	1920	1010	3.5
SV30-101-150-212-E		738	918	2120	1010	3.8
SV30-101-150-232-E		894	1092	2320	1010	4.2
SV30-121-150-192-E		743	923	1920	1210	3.8
SV30-121-150-212-E		738	918	2120	1210	4.2
SV30-121-150-232-E		894	1092	2320	1210	4.6
SV43-101-150-125		350	458	1250	1010	2.3
SV43-101-150-188		738	918	1875	1010	3.4
SV43-101-150-250		950	1166	2500	1010	4.5
SV43-101-150-375		1412	1772	3750	1010	6.8
SV43-121-150-125		350	458	1250	1210	2.5
SV43-121-150-188		738	918	1875	1210	3.8
SV43-121-150-250		950	1166	2500	1210	5.0
SV43-121-150-375		1412	1772	3750	1210	7.5
SV58-121-140-125		350	422	1250	1210	2.0
SV58-121-140-188		738	858	1875	1210	3.0
SV58-121-140-250		950	1094	2500	1210	4.0
SV58-121-140-375		1412	1652	3750	1210	6.1

¹⁾ SV30 three shelves, SV43 two shelves, SV58 one shelf.



Optional glass doors.



Optional shelf lighting.



Ticket strip holder.

OPTIONAL ACCESSORIES

- thermometer
- expansion valves for other refrigerants
- energy saving fans
- mirrored end panel
- partition end panel
- bumper trim for end panel
- shelf with console 300, 400 and 500 mm
- shelf lights
- corner cover
- holders, dividers etc.
- manual night curtains
- automatic control devices
- multiplexing kit
- ticket strip holder
- sliding doors for models SV30 and SV43